



BLD2403TC

**For Driver of Speed Closed – loop
for Brushless DC Motor with Hall Sensor
User Manual**



Introduction

The driver with maintenance-free & long lifetime is suitable to drive three-phase Brushless DC motor with Hall sensor working at less than continuous current 3A and normal voltage from 8VDC to 30VDC, What's more, to drive the motor at low speed can always keep maximum torque, etc. The driver is widely used for electrical automation control field, for example, textile machinery, medical equipment, food machinery, electric tools, garden machinery, intelligent household and so on.

The manual states the function of BLD2403TC, installation, commissioning, maintenance, operation and other aspects content. Please read this manual and familiar with the safety attentions before using the driver.

If any double to use this product, please carefully refer the product manual or call our after-sale service department, we will serve you wholeheartedly.

Safety Precaution

Warning :



Dangerous : Operation mistake may endanger personal safety !



Attention : Operation mistake may lead to equipment damage !

Attention :



Installation : Prevent dust, corrosive gases, conductive objects,

Liquid and flammable materials and maintain good heat dissipation.



Wiring : Please first carefully read the manual, then connecting at the state of power off by professional in order to avoid electric shock.



Prior to power-on : Before power-on, please check and ensure the connecting & power supply voltage is right.



Power-on : After power-on, please do not touch terminals by fingers or any conductor directly due to dangerous high voltage.



Please plug terminals after the lights go out.



Do not operate the hi-pot & insulation resistance testing for the drive.



Do not connect the electromagnetic contactor, solenoid switch into the output circuit.

Contents

Introduction.....	1
Safety Precaution.....	2
Contents.....	3
一. Outline.....	5
1. Model instructions.....	5
2. Function Parameters.....	6
3. Function Features.....	7
二. Port instruction.....	7
1. Interface.....	7
2. Wiring diagram.....	9
3 Insatllation dimension.....	10
三. Function and Use.....	11
1. Factory instruction.....	11
2. Operating instruction.....	11
2.1 External Potentiometer speed control.....	12
2.2 External Voltage speed control.....	12
2.3 External PWM velocity command.....	12
2.4 CAN BUS control.....	13
3. Functional terminal instruction.....	13
3.1 F/R terminal : Positive and negative turing function.....	13

3.2 EN terminal : Enable function.....	14
3.3 BRK terminal : Brake lock function.....	14
3.4 SV terminal : External speed control terminal.....	15
3.5 PG terminal : Motor speed signal output.....	15
3.6 ALM terminal : Alarm output.....	15
3.7 PWR/ALM : Indicator.....	16

— . Outline

The driver is applied to the speed control of brushless DC hall motor. The biggest advantage is to control the motor keeping maximum torque at low speed. In addition, diversity speed adjustment mode, Wide speed adjustment range, fully functional, hardware and software full protection, advantages, etc.

Diversity speed adjustment mode: provide potentiometer speed control, external voltage speed control, external PWM velocity command, CAN BUS speed control and so on modes.

Wide speed adjustment range: Support speed adjustment in the range of 100~20000 rpm; Complete function; With enable, positive and negative turning, braking, motor speed signal input, alarm output and so on functions.

Hardware and software full protection: blocked protection, over voltage protection, under voltage protection, over current protection, over temperature protection, the hall signal fault alarm and so no functions.

2 . Function Parameters

Supply voltage	8~30VDC	
Operating current	Continuous current: 3A, Peak current: 6A (Ambient temperature below 25°C)	
Power range	≤120 W	
Adapted motor	Brushless DC hall motor (120°/240°)	
Working mode	Hall speed closed – loop mode(Factory Default), Open – loop mode(Optional)	
Speed adjustment mode	Support external potentiometer speed control, external voltage speed control and PWM velocity command.	
Speed range	100 ~ 20000 rpm	
Protective function	Over voltage protection, Under voltage protection, Over current protection, Over temperature protection, Soft – Start and hall signal fault alarm function.	
Working environment	application	No corrosive, flammable, explosive, conductive gas, liquid and dust.
	temperature	-10°C ~ 70°C
	Humidity	No more than 85% RH
Heat dissipation mode	Natural cooling or external radiator.	
Dimension	98×60×24.5(unit: mm)	

3 . Function Features

- 1) The driver takes advantage of hall signal for closed-loop speed control, also can achieve the maximum torque at low speed.
- 2) Wide speed adjustment range, support 100~20000 rpm speed range.
- 3) Provide soft start and stop function, softer start and stop, higher security.
- 4) Wide voltage input range, adapt to 8~30V DC power supply.
- 5) High current driving ability, continuous rated current up to 3A, the peak current can be up to 6A.
- 6) Support External Potentiometer, External Voltage and External PWM velocity command.
- 7) Provide over voltage, under voltage, over current, over temperature, hall sensor error protection alarm function.
- 8) Support CAN2.0B protocol.

In addition, we can provide fast custom service according to the customer's specific requirement.

二 . Port instruction

1 . Interface

interface	Pin name	Instruction
Power		
interface	VDC	12~40V DC input

	GND	Power Ground
Motor interface	Motor U	Motor phase – U
	Motor V	Motor phase – V
	Motor W	Motor phase – W
	PE	Shield Ground
	Hall U	Hall signal phase - U
	Hall V	Hall signal phase - V
	Hall W	Hall signal phase - W
	E+5V	5V power output (maximum current 200mA)
	GND	5V Ground
Speed Controlling interface	F/R	Positive and Negative turning control
	EN	Enable Control
	BRK	Brake Control
	GND	External speed controlling Ground
	SV	0 ~ 5 V analog voltage signal or PWM input
	+5V	5 V Power output (maximum current 500mA)
	PG	Motor speed pulse output
	ALM	Alarm output
Others	CAN	CAN BUS interface
	PWR/ALM	Indicator

2 . Wiring diagram

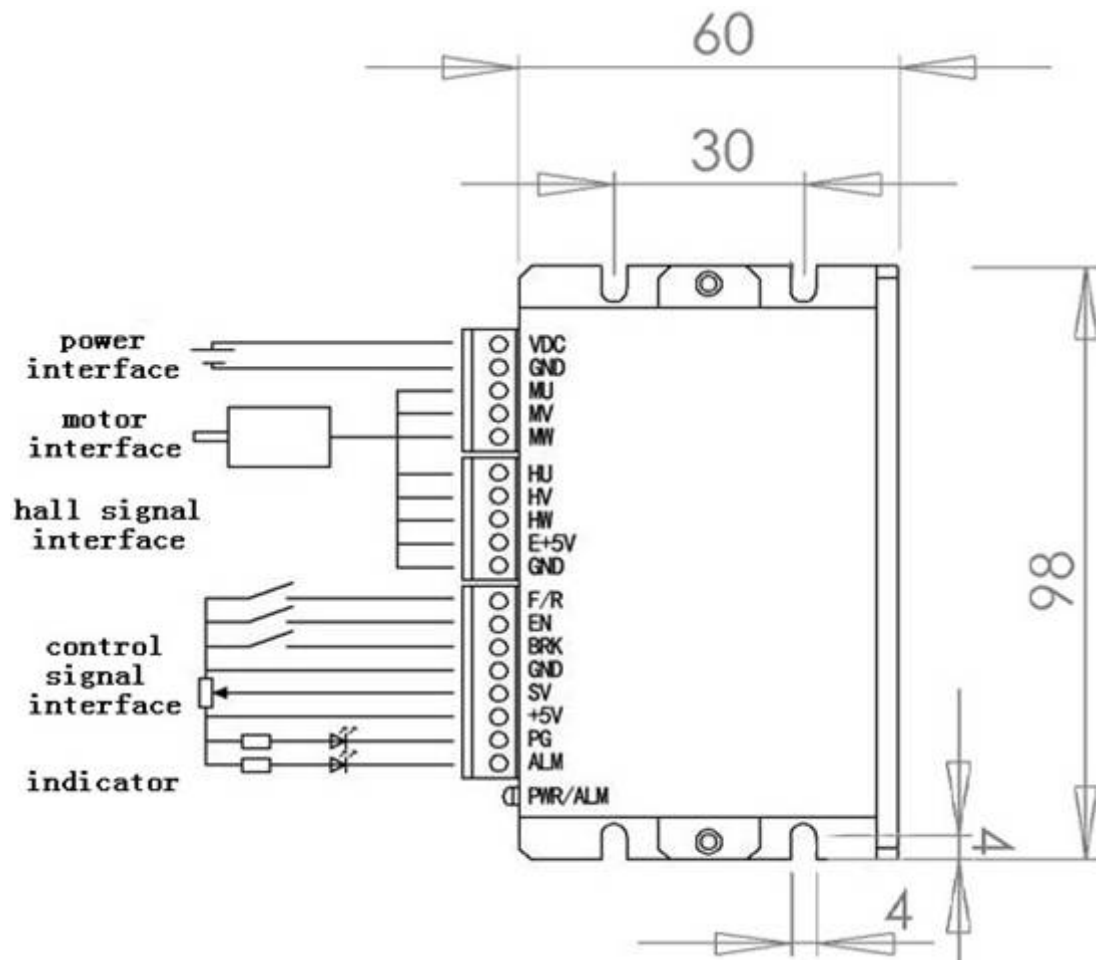

Figure 1: BLD2403TC wiring diagram

3 . Installation dimension

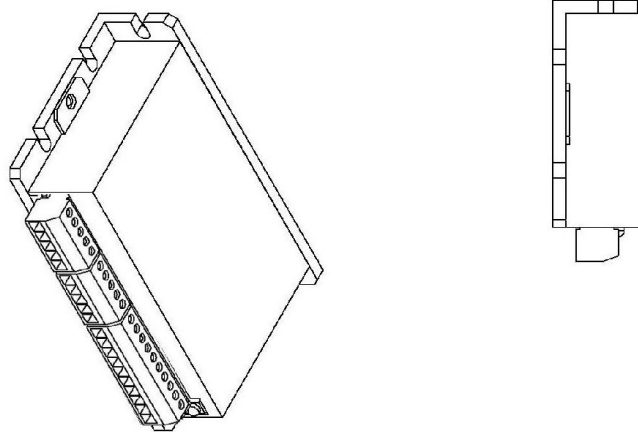
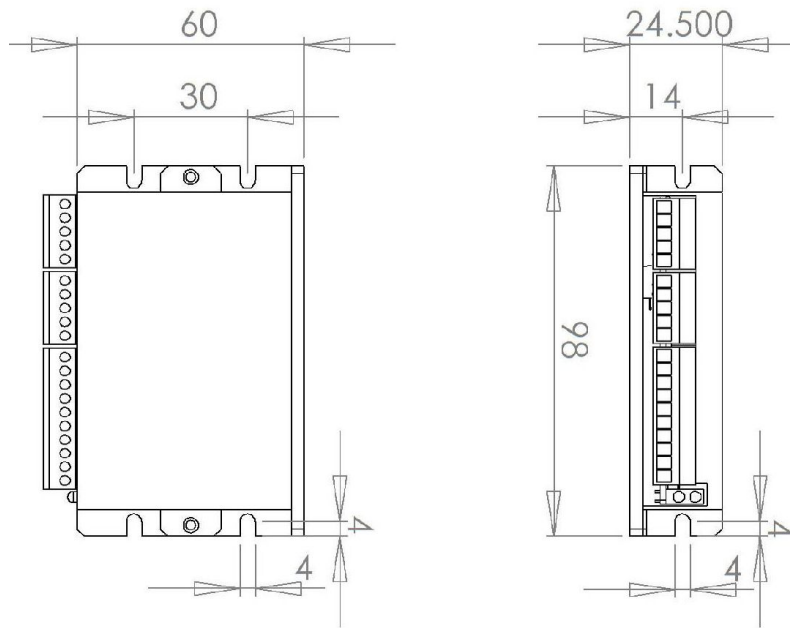

Figure 2: Driver installation dimensions

≡ . Function and Use

1 . Factory instruction

BLD2403TC driver working mode has two kinds: Speed closed-loop working mode and speed open – loop working mode. The factory default working mode is hall speed closed loop. When using open loop mode, please open the driver cover and pull out the built-in SET1&SET2 jumper cap to normal control.

In order to achieve a lower speed control, BLD2403TC driver use a completely new direction recognition speed control mode, the default support 120° motor, If connecting 240° motor, the motor will turn rapidly, There are two ways to solve:

(1) Use EzCANDebugger PC software to configurate motor in positive direction, then restart the driver.

(2) open driver cover and pull out built-in jumper SET1 or SET2, then restart the driver.

In addition, BLD2403TC driver only support 120°/240° hall signal brushless motor. If it is 60°/300° hall signal, all the three hall lines will show 0 or 1, the driver will show as error.

2 . Operating instruction

The driver provide four speed modes: External Potentiometer speed control, External Voltage speed control, External PWM velocity command and CAN BUS

speed, Users can choose one of them in accordance with their application.

2.1 External Potentiometer speed control

First, connect the enable(EN) with control signal ground(GND), take wiring diagram for reference, connect motor terminals including phase parts(Motor U, Motor V, Motor W) and hall(Hall U, Hall V, Hall W, E+5V, GND)with driver terminals in correspond. Connect 10~50K Ω external potentiometer to the external control signal terminal, Note that the control fixed point(intermediate interface) should connect to drive SV port, the other two with GND and 5V ports. After power on, use the external potentiometer to adjust speed.

2.2 External Voltage speed control

First, connect the enable(EN) with control signal ground(GND), take wiring diagram for reference, connect motor terminals including phase parts(Motor U, Motor V, Motor W) and hall(Hall U, Hall V, Hall W, E+5V, GND)with driver terminals in correspond. After power on, use PLC, MCU device to input analog voltage to SV port. Note that the input to SV port analog voltage range is 0~5V.

2.3 External PWM velocity command

First, connect the enable(EN) with control signal ground(GND), take wiring diagram for reference, connect motor terminals including phase parts(Motor U,

Motor V, Motor W) and hall(Hall U, Hall V, Hall W, E+5V, GND) with driver terminals in correspond. Input a 5V fixed frequency digital signal(PWM) between SV and GND to adjust speed. Note: PWM frequency must fix at a constant frequency of 1kHz~5KHz. By adjusting the duty cycle of the PWM waves to adjust speed. When the given input duty cycle is 0%, the motor will stop running. The greater input duty cycle is the higher motor speed is. When input 99% duty cycle, the motor speed is the maximum.

2.4 CAN BUS control

Control though CAN BUS configuration mode: communication control or external control. When use the communication control mode, all external control port failure. Specific operational guidelines please refer to 《The EzCAN Debugger instructions》 and 《EzCAN text agreement》 .

3 . Functional terminal instruction

3.1 F/R terminal: Positive and negative turning function

By controlling on and off of the F/R terminal and the GND terminal can control the running direction of the motor shaft.

Take hall 120° motor test for example: When disconnect the F/R terminal from the GND terminal, the motor is clockwise running(positive before the motor shaft axial plane), When connect the F/R terminal with GND terminal, the motor is counterclockwise running.

In addition, though the CAN BUS, it can join the acceleration and deceleration time, and can be coherent steering control in the motor running without the need to wait the motor stopped movement before running.

3.2 EN terminal : Enable function

By controlling on and off of the EN terminal and GND terminal can control the run and stop of the motor.

Connect the EN terminal with GND terminal, the driver is into enable state, it can further control the motor speed adjusting, reversing, brake and so on. When disconnect the EN terminal from GND terminal, the driver stop the control of motor, the running motor will stop naturally due to mechanical inertia.

3.3 BRK terminal : Brake lock function

By controlling on and off of the BRK terminal and GND terminal can control the motor shaft brake and operation.

When BRK terminal and GND terminal is disconnected, the motor running. When BRK terminal and GND terminal is connected together, the motor shaft stop locking immediately. Please note that due to the brake locking function impacts on both electrical and mechanical, if no special locking function impacts on both electrical and mechanical, if no special downtime request, recommend a natural stop.

3.4 SV terminal : External Speed control terminal

SV terminal is used for External Potentiometer speed control, External Voltage speed control, and External PWM velocity command.

3.5 PG terminal : Motor speed signal output

The driver provide motor speed pulse signal. PG terminal is motor speed pulse output, the open collect signal. When using, connect 3~10k Ω pull-up resistor between PG terminal and +5V terminal to measure output frequency.

Calculation method :

Motor speed = $60 \times \text{signal output frequency} / \text{pulse number per revolution}$;

Pulse number per revolution = Motor poles $\times 3$.

For example:

When customer choose 2 pairs of poles(4 - pole) motor, then the motor pulses per revolution is $2 \times 3 = 6$, When the output signal frequency is 600 Hz, the motor speed is $60 \times 600 / 6 = 6000$ rpm.

3.6 ALM terminal : Alarm output

ALM terminal is alarm output terminal, the open collector signal, When using, connect 3 ~ 10k Ω pull - up resistor between ALM terminal and +5V terminal.

External wiring shown as below:

1)ALM alarm signal output buzzer connection as shown in Figure 3:

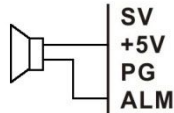

Figure 3 : ALM alarm signal buzzer connection

2)ALM alarm signal output digital signal connection as shown in Figure 4:

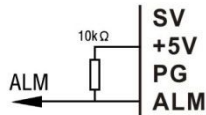

Figure 4 : ALM alarm signal and digital signal connection

3)ALM alarm signal output indicator connection as shown in Figure

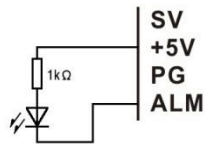

Figure 5 : ALM alarm signal indicator connection

When the driver over current, over voltage, under voltage, short circuit, locked – rotor,, motor control failure, it will automatically into protection state, stop the motor running, and output an alarm signal to the ALM, at the same time, the red light is lit up, the maximum to protect the safety of the driver and motor. This alert happen, please cut off the power immediately, check whether the wiring errors and the power supply is within the prescribed scope.

3.7 PWR/ALM : Indicator

The green LED is power indicator, when power on, the driver work properly and the green LED lighting on. The red LED is fault indicator, if the driver fails, the

green light will be off, and the red light flash at a certain cycle. The number of flashing represents different fault information. Specific meaning shown in the following table:

NO	Alarm display	Fault instruction	resolution
1	The red light flashing once	The power supply is more than 40V, the driver will come into reset an over voltage protection stage.	EN recovery or restart.
2	The red light flashing twice	The voltage is over 10V, the driver will come into an over voltage protection stage.	EN reset recovery or restart.
3	The red light flashing three times	The current is over 15A, the driver will come into an over current protection stage.	EN reset recovery or restart.
4	The red light flashing four times	The temperature is over 70°C, the driver will come into an over temperature protection stage.	EN reset recovery or restart.
5	The red light flashing five times	Hall signal all low or high state	Take reference of the instruction and check the hall wiring connect. Restart when correctly.
6	The red light is on	Initialization error or hardware error.	restart
7	The green light flashing	The motor can not reach specified target speed.	Reduce the target speed or reduce the load.